

D U C T M A T E

Access Doors

FOR PRICING AND AVAILABILITY CONTACT
ALLSTATE INSULATION 888-881-4822
E-MAIL allstateinsulation@yahoo.com



ACCESS DOORS

Square Framed Access Doors

Hinged and Cammed Models

- Double gasketed
- Insulated
- Competitively priced
- Precision designed and manufactured
- Variety of sizes available
- Available in Specialty Metals



DUCTMATE[®]

Industries, Inc.

Hinge & Cam

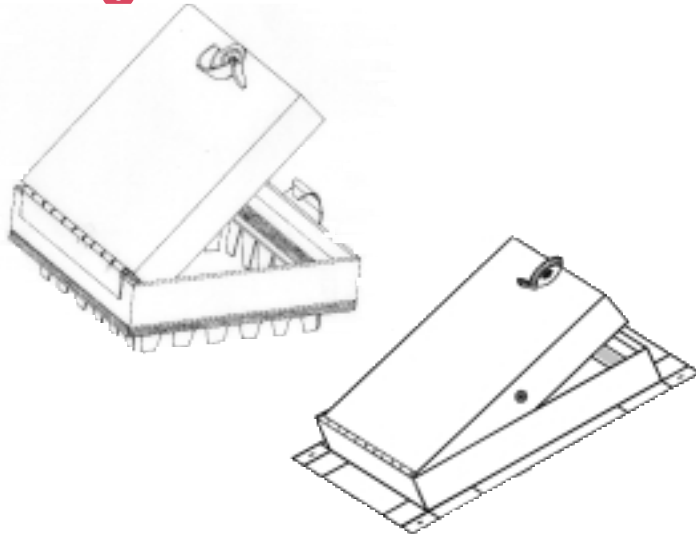

DESCRIPTION

Low pressure access door for rectangular duct.

BASIC USE

To provide easy access into air ducts and units. This door was developed as an inexpensive alternative to the Ductmate Sandwich® Access Door, for low pressure applications.

SPECIAL CHARACTERISTICS

Insulated
Double gasketed
Meets SMACNA requirements for low pressure doors
Dovetail frames are available for Metal Ductwork, 1" Duct Board or 1 1/2" Duct Board.
Press-On frames are available for metal ductwork only.

TECHNICAL INFORMATION

- a. **DOOR**
Consists of two, 24 gauge galvanized steel panels mechanically locked together.
- b. **INSULATION**
High density fiberglass insulation with UL classification: FHC25/50.
- c. **GASKET**
Closed cell neoprene gasket is UL94HF1 listed with a service temperature range of (ASTM D746) -20° F to 200° F. The gasket is bonded to the inside of both the Dovetail and Press-On frames and also to the outside of the Dovetail frame only.
Double Sided Adhesive Gasket: Closed cell neoprene is UL94HF1 listed with a service temperature range of -100°F to 200°F. This gasket is bonded to the outside of the Press-On frame only.
- d. **DOVETAIL FRAME**
Frames measuring 6" x 6" to 12" x 12" are manufactured from 24 gauge galvanized steel. Frames measuring 14" x 14" to 24" x 24" are manufactured from 22 gauge steel. All frames are manufactured with spotwelds at each corner for increased strength and an improved Dovetail design for easy installation on metal duct, 1" Duct Board or 1 1/2" Duct Board.
- e. **PRESS-ON FRAME**
Frames measuring 6" x 6" to 12" x 12" are manufactured from 24 gauge galvanized steel. Frames measuring 14" x 14" to 24" x 24" are manufactured from 22 gauge galvanized steel. A durable double sided adhesive gasket allows for easy installation to metal ductwork.
- f. **HINGE**
Full length galvanized steel piano hinge is secured to both the frame and the door with three spot welds.
- g. **CAM & LATCH**
The cam is manufactured from 16 gauge galvanized steel and the latch is manufactured from 20 gauge galvanized steel. Each cam is secured to the door with a rivet. The latch is secured to the frame with two spot welds.

Cam Latches

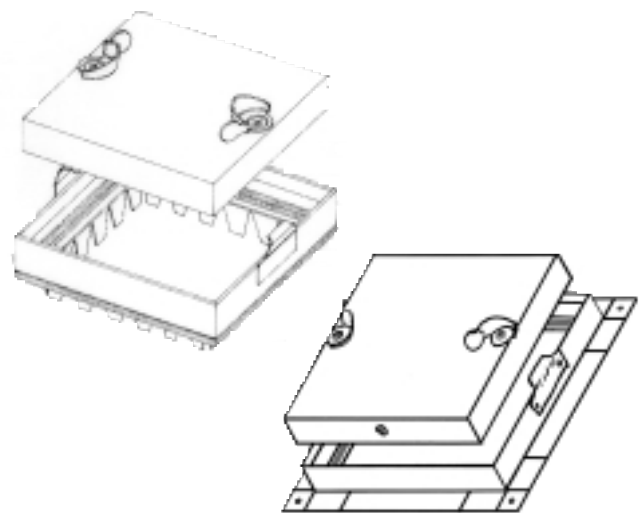

DESCRIPTION

Low pressure access door for rectangular duct.

BASIC USE

To provide easy access into air ducts and units. This door was developed as an inexpensive alternative to the Ductmate Sandwich® Access Door, for low pressure applications.

SPECIAL CHARACTERISTICS

Insulated
Double gasketed
Meets SMACNA requirements for low pressure doors
Dovetail frames are available for Metal Ductwork, 1" Duct Board or 1 1/2" Duct Board.
Press-On frames are available for metal ductwork only.

TECHNICAL INFORMATION

- a. **DOOR**
Consists of two, 24 gauge galvanized steel panels mechanically locked together.
- b. **INSULATION**
High density fiberglass insulation with UL classification: FHC25/50.
- c. **GASKET**
Closed cell neoprene gasket is UL94HF1 listed with a service temperature range of (ASTM D746) -20° F to 200° F. The gasket is bonded to the inside of both the Dovetail and Press-On frames and also to the outside of the Dovetail frame only.
Double Sided Adhesive Gasket: Closed cell neoprene is UL94HF1 listed with a service temperature range of -100°F to 200°F. This gasket is bonded to the outside of the Press-On frame only.
- d. **DOVETAIL FRAME**
Frames measuring 6" x 6" to 12" x 12" are manufactured from 24 gauge galvanized steel. Frames measuring 14" x 14" to 24" x 24" are manufactured from 22 gauge steel. All frames are manufactured with spotwelds at each corner for increased strength and an improved Dovetail design for easy installation on metal duct, 1" Duct Board or 1 1/2" Duct Board.
- e. **PRESS-ON FRAME**
Frames measuring 6" x 6" to 12" x 12" are manufactured from 24 gauge galvanized steel. Frames measuring 14" x 14" to 24" x 24" are manufactured from 22 gauge galvanized steel. A durable double sided adhesive gasket allows for easy installation to metal ductwork.
- f. **CAM & LATCH**
The cam is manufactured from 16 gauge galvanized steel and the latch is manufactured from 20 gauge galvanized steel. Each cam is secured to the door with a rivet. The latch is secured to the frame with two spot welds.

PACKAGING INFORMATION

Hinge & Cam

SIZE	PART NO.	NO. PER CARTON	LBS. PER CARTON
6" x 6"	FD*H6GA	20	31
8" x 8"	FD*H8GA	20	45
10" x 10"	FD*H10GA	10	30
12" x 12"	FD*H12GA	10	39
14" x 14"	FD*H14GA	10	50
16" x 16"	FD*H16GA	5	30
18" x 18"	FD*H18GA	5	38
20" x 20"	FD*H20GA	5	45
24" x 24"	FD*H24GA	5	60

* 1 for 1" Duct Board; 15 for 1 1/2" Duct Board, P for Press-On frames

** Note: Two cams opposite the hinge for doors larger than 14"

Cam Latches

SIZE	PART NO.	NO. PER CARTON	LBS. PER CARTON
6" x 6"	FD*C6GA	20	31
8" x 8"	FD*C8GA	20	45
10" x 10"	FD*C10GA	10	30
12" x 12"	FD*C12GA	10	39
14" x 14"	FD*C14GA	10	50
16" x 16"	FD*C16GA	5	30
18" x 18"	FD*C18GA	5	38
20" x 20"	FD*C20GA	5	45
24" x 24"	FD*C24GA	5	60

* 1 for 1" Duct Board; 15 for 1 1/2" Duct Board, P for Press-On frames

** Note: Four cams on doors larger than 14"

Rectangle Sizes are available for both hinge & cam, and cam latch models.

PRODUCT GUARANTEE

All Square Framed Access Doors are guaranteed against defective material.

INSTALLATION INSTRUCTIONS FOR DOVETAIL FRAMES

1. Trace the frame of the access door onto the duct.



2. Using a hand held plasma cutter or by conventional methods, cut the hole for the frame.



3. Open the door and place the frame into the hole you cut in step 2.



4. Bend over all of the dovetails on the frame with a hammer to ensure a tight fit.



5. Close the door and latch.



INSTALLATION INSTRUCTIONS FOR PRESS-ON FRAMES

1. Without removing the cover from the adhesive backed gasket, place the opened doorframe on the duct and trace around the inside of the frame.



2. Using a hand held plasma cutter or by conventional methods, cut the hole for the frame.



3. Remove the cover from the adhesive backed gasket tape.

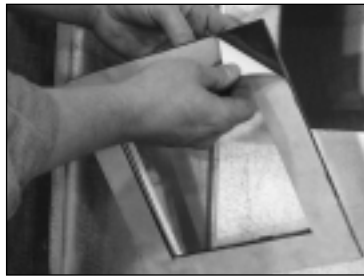

4. Open the door and place the frame over the hole you cut in step 2.

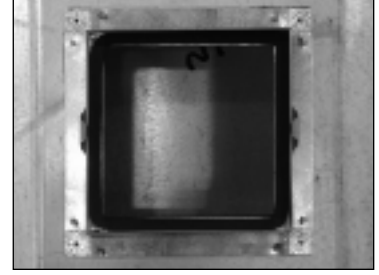

5. Using zip screws, permanently attach the frame to the ductwork. Doors 16" and smaller require one screw at each corner and one at center on each side. Doors 18" to 24" require one screw at each corner with two screws evenly spaced on each side of the frame.



6. Close the door and latch.



E. MONONGAHELA, PA
1502 Industrial Drive
E. Monongahela, PA 15063-9709
800-245-3188
724-258-0500
FAX: 724-258-5494

LODI, CA
810 S. Cluff Avenue
Lodi, CA 95240-3141
800-344-3270
209-333-4680
FAX: 209-333-4678

www.ductmate.com



Distributed By: